

PRODUCTION, SERVICE AND INNOVATION



**ONE SOLUTION
FOR ALL LOCATIONS**



UNIVERSAL ENCLOSURE

- Soft microfiber lining protects every millimeter of your tablet and prevents scratches
- Manufactured in robust steel
- Security system with lock



Specs:

- Physical dimension when closed:
219mm(W) x172mm(D) x37mm(T)
- Physical dimension when opened:
219mm(W) x172mm(D) x37mm(T)





DESIGN STATION

The Design Station was created with minimalism and modernity aesthetics at the front and center of the creation process.

Keeping your tablet safe from damage and theft, the DESIGN STATION enhances your brand image through the installation of modern technology.

- A** Heavy steel construction
- B** Cable security and management
- C** Tilt display +/- 15°



Dimension

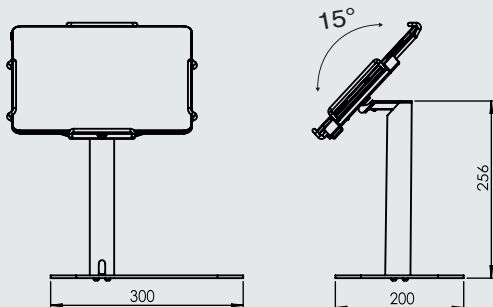

Specs

- Secure key lock system (2 keys)
- Color: Black, Gray
- Non-slip rubber feet
- Compatible devices pag. 13

POS iSTAND

Simple, secure, reliable Point - of - Sale for your shop.



- A** Stand alone tablet holder solution
- B** Counter mounting holes
- C** Tilt -10° / $+10^{\circ}$
- D** Friction torque hinge

Dimension

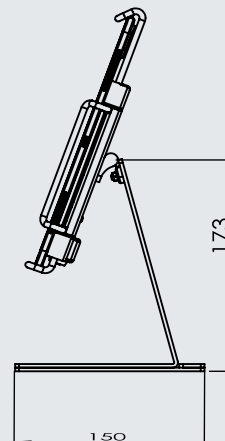

Specs

- Secure key lock system (2 keys)
- Color: Black
- Non-slip rubber feet
- Holes and screws kit for counter installation
- Compatible devices pag. 13



ALL-IN-ONE



- A** Printer slot 14x20x15cm (WxLxH)
- B** Tilt -15° / +15°
- C** Second tablet holder (accessory)
- D** Heavy steel construction

Dimension

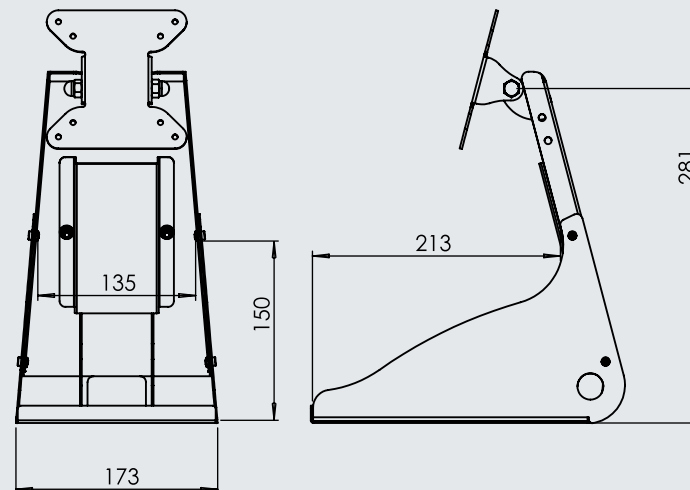

Specs

- Secure key lock system
- Color: Black
- Non-slip rubber feet
- Integrated cable security and management
- Compatible devices pag. 13

DESK TABLET

- A** Base installation holes drilling and 3M adhesive
- B** Kensington security slot
- C** Tilt and Rotation functionality
- D** Cable security and management



Dimension

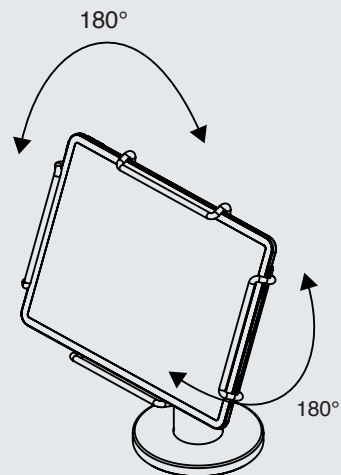
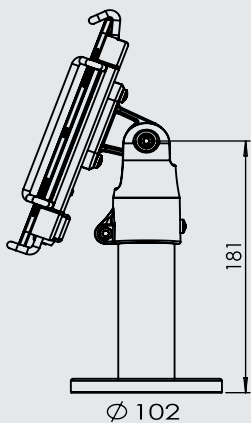

Specs

- Secure key lock system (2 keys)
- Color: Black
- Non-slip rubber feet
- Integrated cable security and management
- Compatible devices pag. 13



MULTIFUNCTIONAL TABLET STATION



- A** SN-Universal tablet holder with secure key
- B** Integrated cable security and management
- C** Printer plate holder
- D** Adjustable length arm with barcode reader holder

Specs

- Secure key lock system (2 keys)
- Color: Black
- Adjustable arm mounting
- Integrated cable security and management
- Compatible devices pag. 13

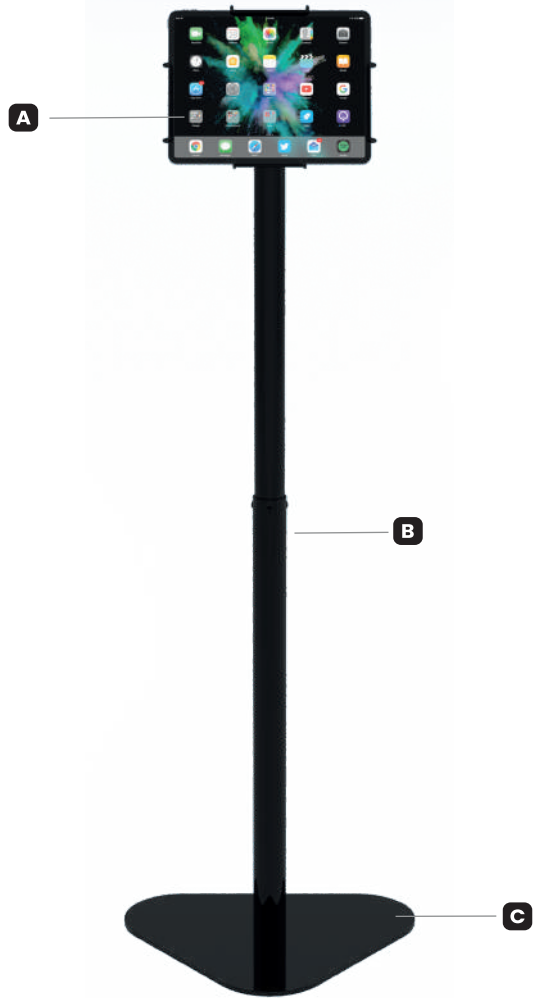

FLOOR TABLET STAND

- A** Secure tablet holder with key
- B** Cable management and height adjustable
- C** Heavy steel base for floor installation

Dimension

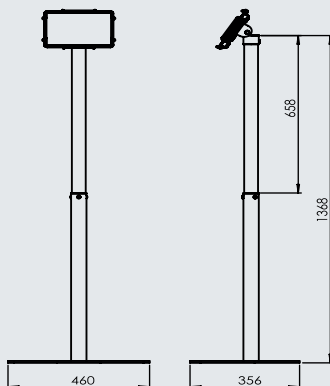

Specs

- Secure key lock system (2 keys)
- Color: Black
- Adjustable height from
- Compatible devices pag. 13





TABLET POLE DISPLAY

Improve customer service and the company's image, through the secure installation of tablets.



- A** Base installation holes drilling and 3M adhesive
- B** Cable security and management
- C** Tilt display +/- 45°
- D** Table clamp mounting (accessory)



Dimension

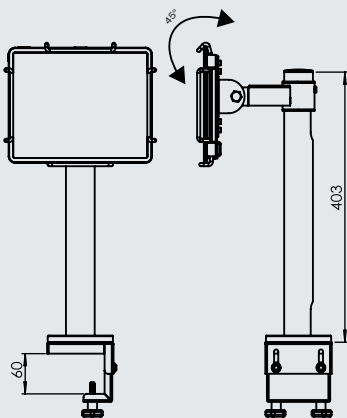

Specs

- Secure key lock system (2 keys)
- Color: Black
- Double tablet holder (accessory)
- Integrated cable security and management
- Compatible devices pag. 13

TABLET DELIVERIES STATION

The seamless solution to housing your multiple tablets in one minimalistic station.

Designed for your multiple food/order delivery tablets allowing you to keep your workplace clutter free.



- A** Base installation holes drilling and 3M adhesive
- B** Safe and secure tablet installation
- C** Cable security and management
- D** Table clamp mount (accessory)

Dimension

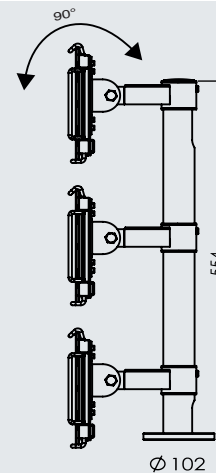

Specs

- Secure key lock system (2 keys)
- Color: Black
- Tilt display
- Integrated cable security and management
- Compatible devices pag. 13



WALL TABLET MOUNT



- A** Secure tablet installation with key
- B** Installation module for wall
- C** Tilt display +/- 5°

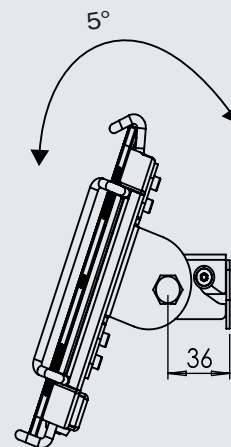

Specs

- Secure key lock system (2 keys)
- Color: Black
- Tilt display
- Integrated cable security and management
- Compatible devices pag. 13

TESTED PRODUCTS



- iPad Pro 12,9 (5th Gen.)
- iPad Pro 12,9 (4th Gen.)
- iPad Pro 12,9 (3a Gen.)
- iPad Pro 11 (3a Gen.)
- iPad Pro 11 (2a Gen.)
- iPad Pro 11 (1a Gen.)



Apple iPad 7th gen,
8th gen (10.2")



Windows Surface pro
7 (12.3")



- iPad Air 2 (9.7")
- iPad Air (3a Gen.)
- iPad Mini 4



Samsung Galaxy
Tablet A (10.1")



Windows Surface Go
Pro (10")



- iPad Pro 10.5"

TABLET COMPATIBILITY DIMENSION

- The enclosure is compatible to all tablets which are equal or smaller 290(W) x 212(H) x 9(D) mm;
- The enclosure is compatible with larger tablets which are equal or smaller than 295(W) x 215(H) x 6.5(D) mm

TO DISCOVER THE FULL RANGE OF RETAIL PRODUCTS
PLEASE VISIT WWW.RETAILPOLE.COM/EN/PRODUCTS/
OR BY SCANNING THE QR CODE.



SCAN ME

Via Rivera, 62 – 20841 Carate Brianza (MB) – Italy
Tel: 0362 912585
Email: info@snsystems.it
WWW.RETAILPOLE.COM
WWW.SNSYSTEMS.IT